

SPECIFICATION

COMMERCIALY AVAILABLE

ITEM: SAW BAND PASS
 PART NUMBER: SF1747075A
 RoHS

ISSUED / REVISION	ENGINEER APPROVED	DOCUMENT CHECKED	DRAFTSMAN
09/25/2019 ^(ASM)			

FILTRONETICS Inc

1. Electrical Specifications:

Index	Unit	Min	Typical	Max	
Center Frequency	MHz	-	1747.50	-	
Insertion Loss	dB	-	2.6	4.0	
Bandwidth	MHz	-	75	-	
Amplitude Ripple	dB	-	1.6	2.5	
Input / Output VSWR	-	-	1.8	2.5	
Attenuation: (Reference level from 0 dB)	10 – 1670 MHz	dB	15	23	-
	1670 – 1690 MHz	dB	6	23.9	-
	1805 – 1880 MHz	dB	6	24	-
	1880 – 4500 MHz	dB	15	25	-
	4500 – 5000 MHz	dB	10	14	-
Package	mm	3.0 x 3.0 x 1.4			

2. Dimension:

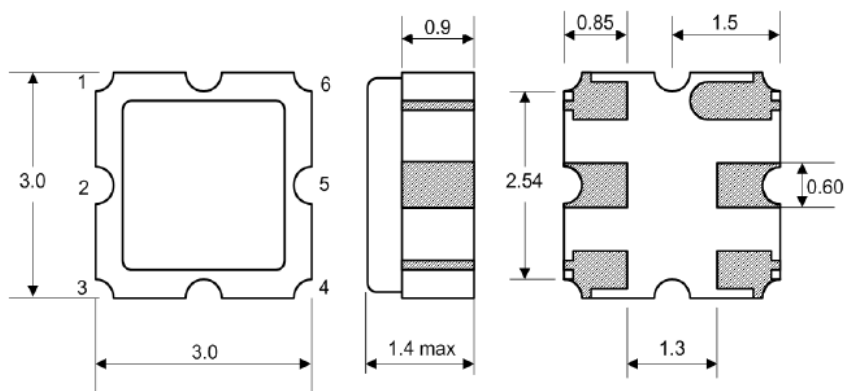

2 : Input 5 : Output
 1, 3, 4, 6 : Ground

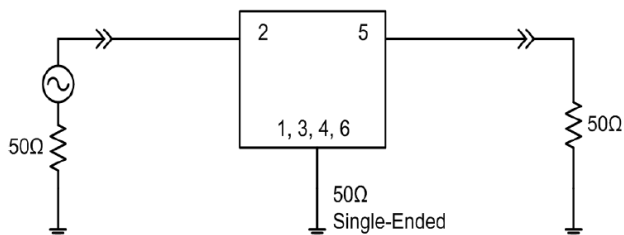

No Matching required
 Source / Load Impedance = 50Ω
 Ambient Temperature = 25°C

3. Typical Performance:

