

# SPECIFICATION

ITEM: LC BAND PASS FILTER

PART NUMBER: FN-4674W

ISSUED / REVISION	ENGINEER APPROVED	DOCUMENT CHECKED	DRAFTSMAN
10/25/2019 <sup>(PG)</sup>	11/26/2019 <sup>(TG)</sup>	10/28/2019 <sup>(JE)</sup>	

**FILTRONETICS Inc**

1. Part Number: FN-4674W

2. Electrical Specifications:

Filter Type		LC Band Pass
Center Frequency (Fo)		1100 MHz
3 dB Band Width:		280 MHz Min
Insertion Loss:		3.5 dB Max
Pass Band Ripple:		1 dB Max
Attenuation:	At 512 MHz	60 dB Max
	At 1800 MHz	60 dB Max
Input Power:		0 dBm Max
Impedance:		50 Ohms
Operating Temperature:		- 20°C to +85°C
Workmanship:		J-STD-001

3. Mechanical Package Example Styles:

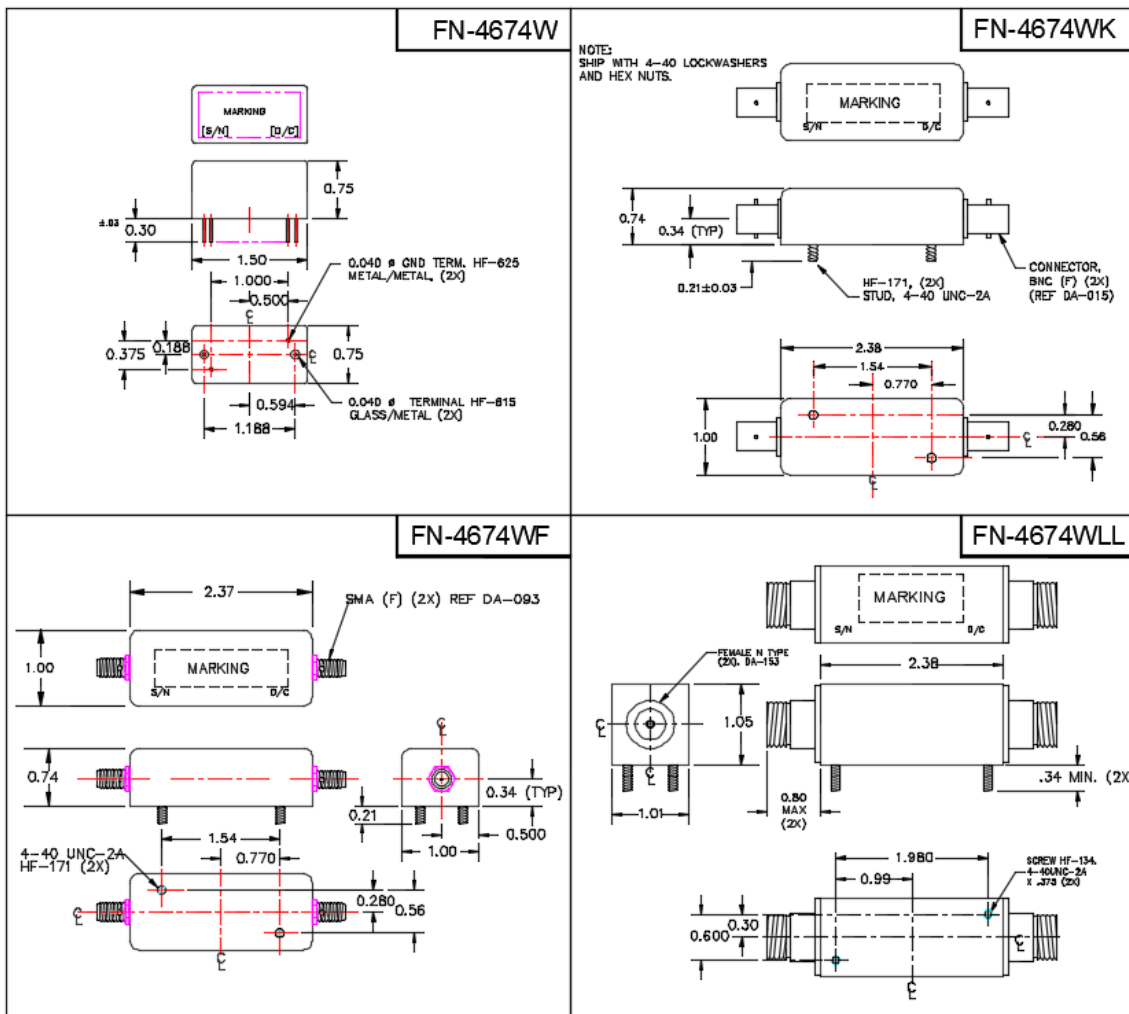

4. Theoretical Response Plot:

