

SPECIFICATION FOR APPROVAL

**ITEM: DIELECTRIC CERAMIC FILTER
PART NUMBER: CFD-154216439**

ISSUED	CHECKED	CHECKED	CHECKED	APPROVED

FILTRONETICS Inc

1. APPLICATION

THIS SPECIFICATION APPLIES TO A DIPLEXER USING DIELECTRIC RESONATORS.

2. PART NUMBER

PART NO	CFD-154216439
PACKAGING	PLASTIC TRAY

3. SPECIFICATIONS

NO	ITEMS		Ref.	SPECIFICATION	
1	Center Frequency (Fo)		a1	1542 MHz	1643.5MHz
2	Pass Band		b1	1525~1559MHz	1626.5~1660.5MHz
3	Insertion Loss AT PB		b1	1.6 dB Max	1.6 dB Max
4	Pass band V.S.W.R		b1	1.5 : 1	1.5 : 1
5	Attenuation	At 1525~1559 MHz		-	55dBc Min
		At 1626.5~1660.5 MHz		65dBc Min	-
6	Impedance			50Ω	
7	Maximum Input Power			1 W (+30dBm)	
8	Operating Temperature Range			-40 - +75°C	

4. GRAPHS

S21 LOG MAG NETWORK ANALYZER

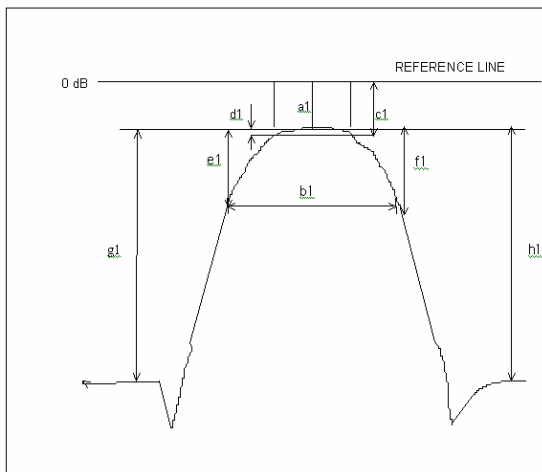

S11 SWR NETWORK ANALYZER

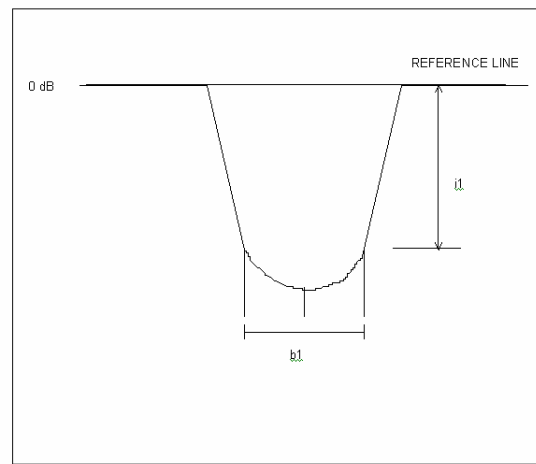

S21 & S11 (INSERTION LOSS, RETURN LOSS, STOPBAND ATTENUATION)

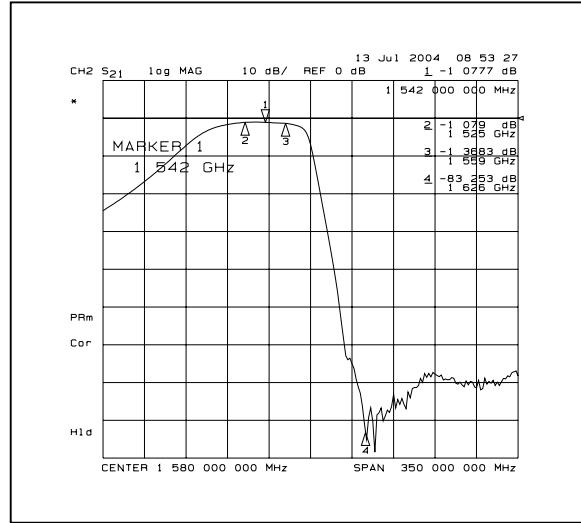
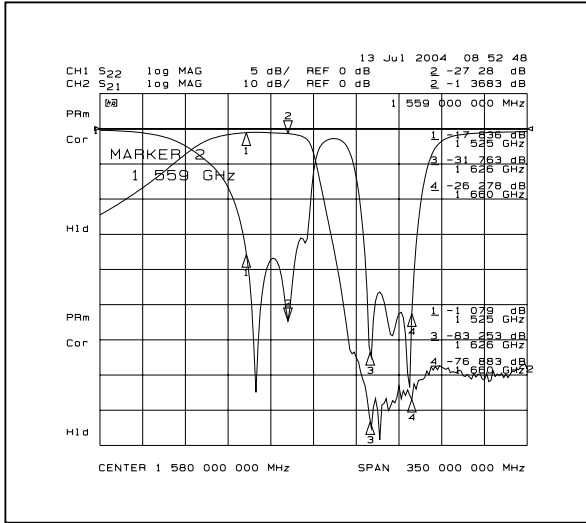

S21 VS S11(TX INSERTION LOSS , STOP BAND ATTENUATION , RETURN LOSS)

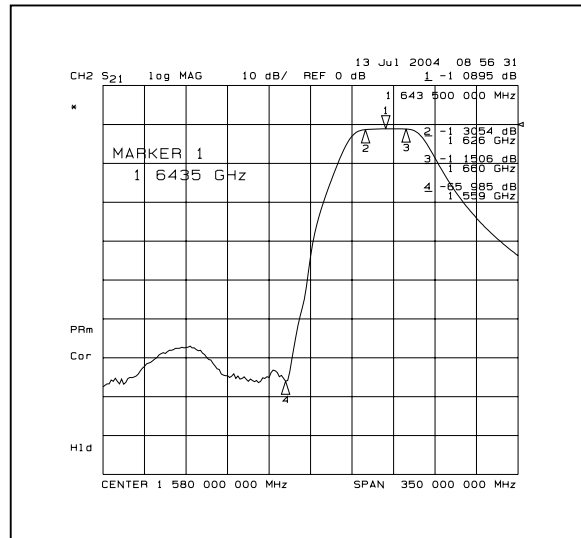
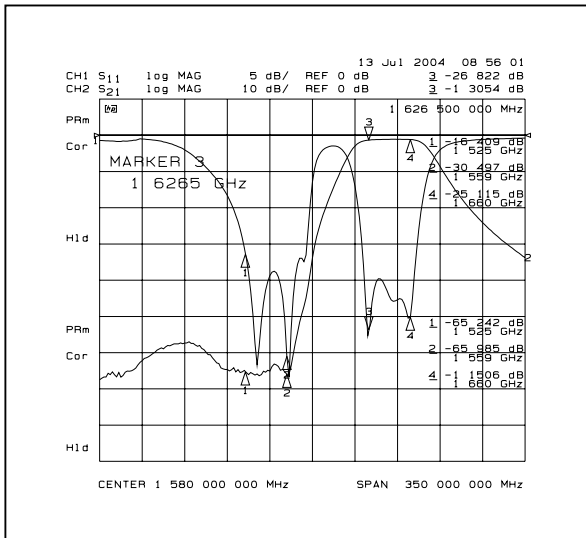

S21 VS S11 (SATURATION , V.S.W.R, SMITH CHART)

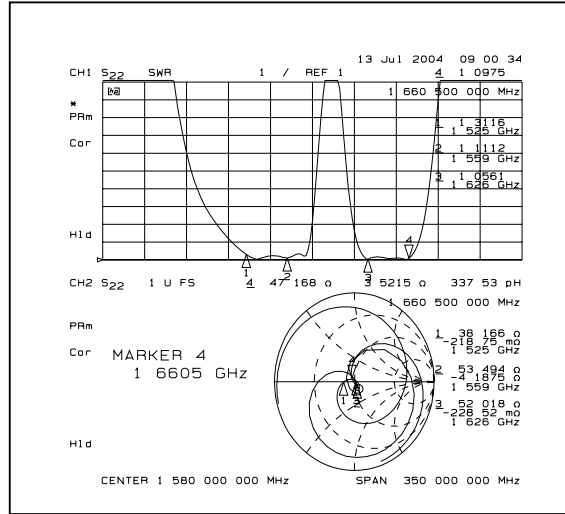
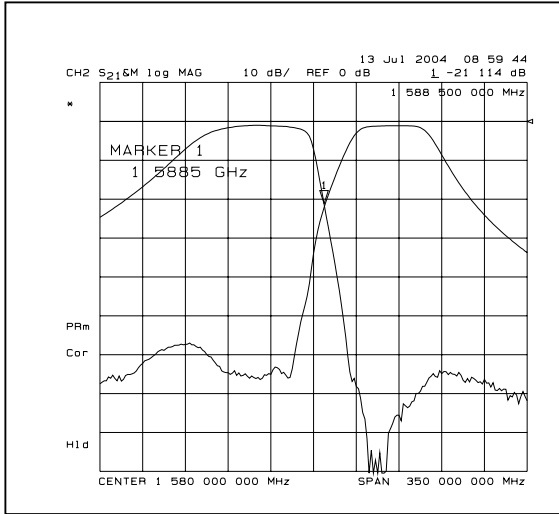

S21 (ISOLATION)

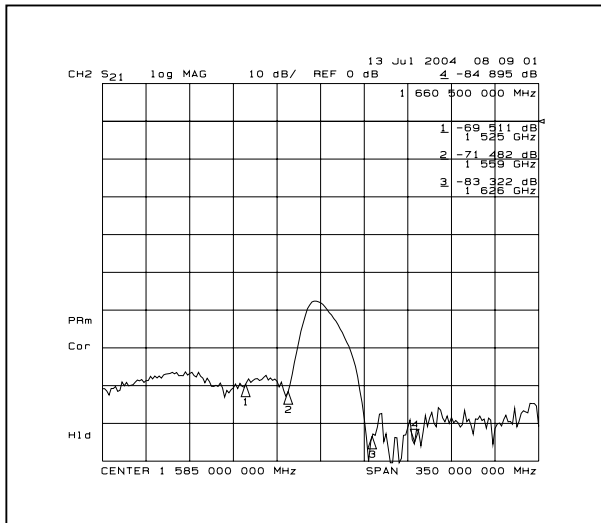

5. DIMENSIONS

IN/OUT LAND

UNIT: MM

TOLERANCE: +/-0.3MM

TOLERANCE: +/-0.5MM

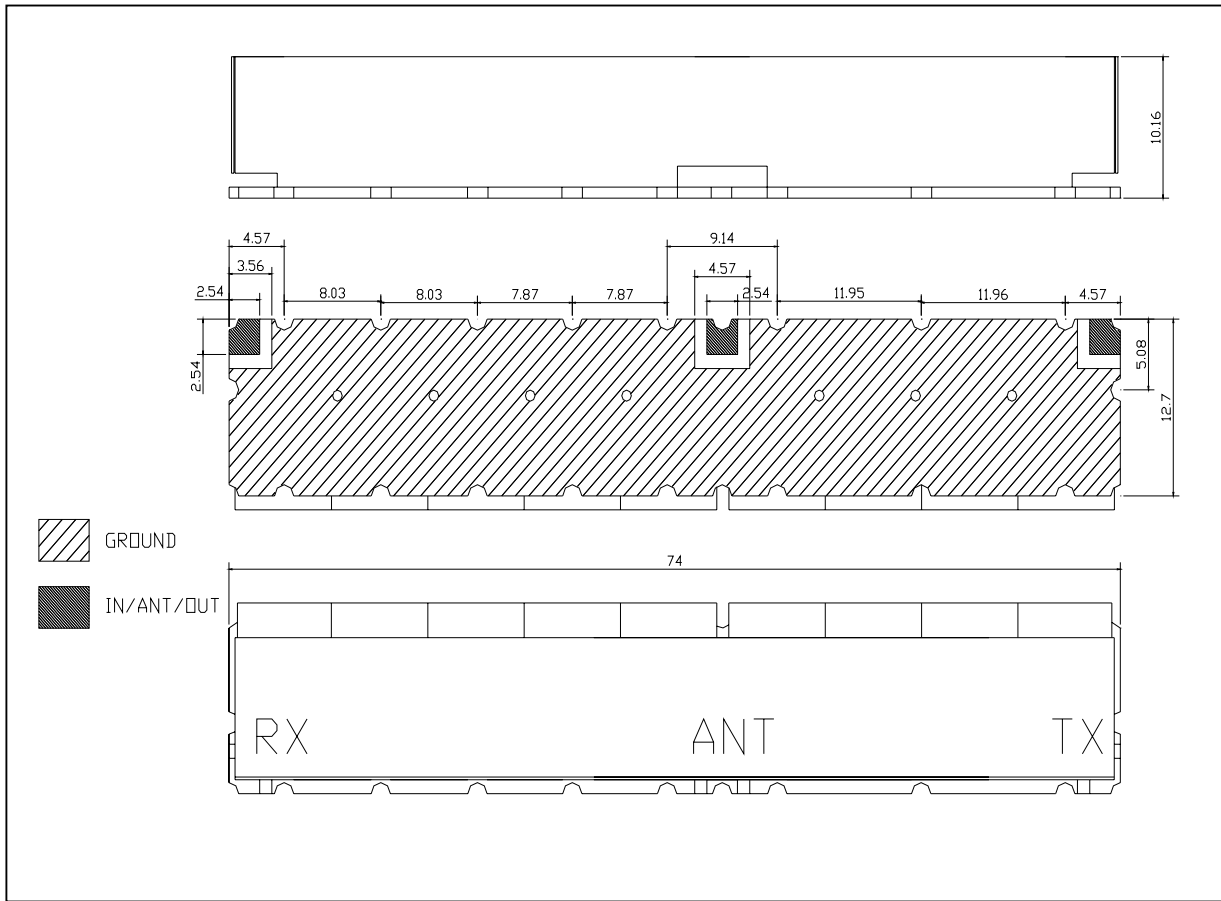

- ※ MATERIAL SPECIFICATION
1. PCB
 - 1) MATERIAL: FR4
 - 2) TERMINALS: Au PLATED
 2. METAL CASE
 - 1) MATERIAL: Sn OR Ni PLATED
 3. RESONATOR
 - 1) COATING MATERIAL: Ag
 - 2) DIMENSION: 8MM x 8MM

- ※ MARKING
- Part Number
Filtronetics

- CAUTIONS:
1. When handling products, be careful not to damage the outer-electrode.
 2. When handling products be careful not to touch the outer-electrode with bare hands or solderability is reduced.
 3. Do not apply excessive pressure or shock to product in handling or in transportation or damage to the ceramic filters may result.

6. DEFINITIONS

TERMS	DESCRIPTION	SPECIFICATION
Center Frequency	The midpoint of through band pass filter pass band, normally expressed as the arithmetic mean of the -3db point. Also called fo.	3. SPECIFICATION
Pass Band Width	The width of the pass band of a filter referenced to the minimum insertion loss point in the pass band. The pass band of a filter is stated as -1.0dB bandwidth.	
Insertion Loss	The loss of the filter, in db, measured at center frequency relative to a through line (0 dB).	
Attenuation	Reduction of RF power through a filter, measured in dB, at desired band and referenced to 0 dB. (Filter to be removed from circuit)	
Pass Band Ripple	Variations in loss in the pass band of the filter, superimposed upon the fundamental shape of the pass band.	
V.S.W.R in Pass Band	The ratio of the maximum value of a standing wave to its minimum value, related to the return loss in pass band.	

7. RELIABILITY TEST AND CONDITIONS

ITEM	TEST CONDITIONS	REQUIREMENTS
Operating Temp. Range	- 45°C ~ + 85°C	- 40°C ~ + 70°C
Resistance to solder heat	Preheat temperature : 120 to 150°C Preheat time: 1 to 1.5 min Solder temperature: 260 +/- 10°C Dipping time: 10 +/- 0.5 sec	No damage such as cracks should be caused in chip element.
Solderability	Preheat temperature: 120 to 150°C Preheat time: 1 to 1.5 min Solder temperature: 235 +/- 5°C Dipping time: 5 +/- 1 sec	More than 80% of the terminal electrode shall be covered with new solder
Heat resistance (High-temperature Load)	Temperature: 85 +/- 2°C Applied voltage: Rated voltage Applied current: Rated current Recovery: 1 to 2hrs of recovery under the standard condition after the removal from test chamber.	No mechanical damage. After test, the device shall satisfy the specification in section 3.
Thermal shock (Temperature cycle)	Conditions for 1 cycle Step 1: + 85°C 15 min Step 2 : - 30°C 15 min Number of cycle: 10	No mechanical damage. After test, the device shall satisfy the specification in section 3.
Humidity Resistance	Temperature: 40 +/- 2°C Humidity: 90 to 95% RH Duration: 96 +/- 5 hrs Recovery: 1 to 2hrs of recovery under the standard condition after the removal from test chamber.	No mechanical damage. After test, the device shall satisfy the specification in section 3.
Vibration	Frequency: 10 ~ 50 Hz Amplitude: 1.52 mm (0.060 inches) Direction: X, Y and Z Time: each 30 min for all directions	No mechanical damage. After test, the device shall satisfy the specification in section 3.

8. REFLOW SOLDERING STANDARD CONDITIONS

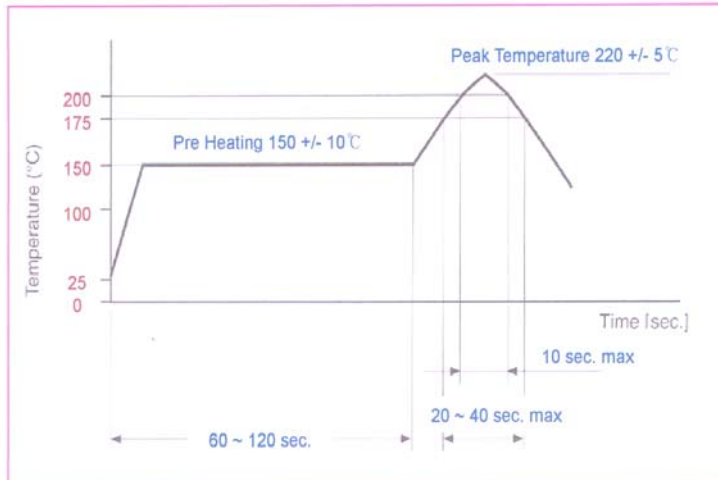

- Measuring point of temperature in-out terminals of the device.
- Reflow Soldering
- Both convection and infrared rays
- Hot air
- Hot plates
- Solder Cream: Sn64/Pb36